

Serial Bluetooth Converter for V.24 (RS-232), RS-422, and RS-485 2-Wire Bus Systems PSI-WL-RS232-RS485/BT

1. Description

The Bluetooth converter provides a quick and easy wireless connection between serial interfaces of the V.24 (RS-232), RS-422, and RS-485 2-wire standard.

The wireless connection can extend up to 150 m and is based on the international license-free Bluetooth standard.

This wireless standard meets high requirements for interference-free data transmission, in particular through the use of the FHSS method (Frequency Hopping Spread Spectrum) with the 2.4 GHz ISM band.

The Bluetooth converter can be used for a wide range of different applications, for example:

- Replacement of simple, serial point-to-point cabling for V.24 (RS-232), RS-422, and RS-485 2-wire interfaces.
- Creation of master/slave multi-drop connections.
- Wireless operation and monitoring for processes.
- Wireless parameterization, and diagnostic and programming connections.
- Replacement of slip ring joints or drag chains.
- Implementation of high-quality electrical isolation between the stations.

The **PSI-WL-RS232-RS485/BT** serial Bluetooth converter is designed for industrial use and features the following performance characteristics:

- Mounting by snapping on to an EN DIN rail
- Supply of 24 V DC or AC
- Transmission speed of up to 187.5 kbps
- Can be set to V.24 (RS-232), RS-422 or RS-485
- Supports all popular 10/11-bit UART data formats
- 3964R-compatible
- External antenna connection for optimum antenna positioning
- Bluetooth access protected by password, fixed device pairing or device access list
- Scalable transmission power (-28 to 20 dBm) for specific localization of the radio cell
- Integrated Bluetooth path diagnostics indicate the signal quality of the radio connection.

 **Bluetooth™**



Should you have any technical questions, please contact us:

PSM HOTLINE: +49 - 52 35 - 31 98 90

FAX: +49 - 52 35 - 31 98 99

E-mail: interface-service@phoenixcontact.com

The **PSI-WL-RS232-RS485/BT** Bluetooth converter is accessed via a second, identical device or via the **PSI-WL-PLUG-RS232/BT** V.24 (RS-232) adapter, which is in the form of a connector. Wireless access via third-party devices, which already have an integrated Bluetooth interface, e.g., PDA, notebook or cell phone, is also supported (see page 2).

2. Application

2.1 Point-to-Point Connections

Point-to-Point Without Termination Device Addressing (V.24 (RS-232), RS-422, etc.)

- Direct programming connection between a laptop and a programmable logic controller (Figure 02).

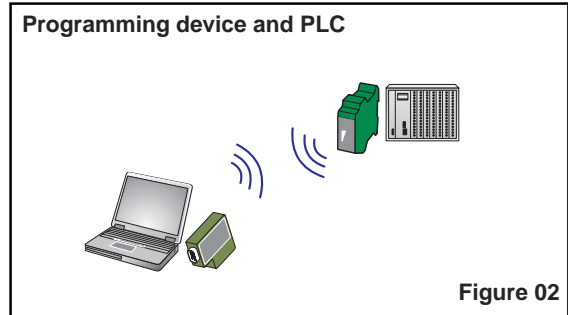

- Data connection between a third-party device with integrated Bluetooth interface (PDA, cell phone, etc.) and an industrial controller (Figure 03).

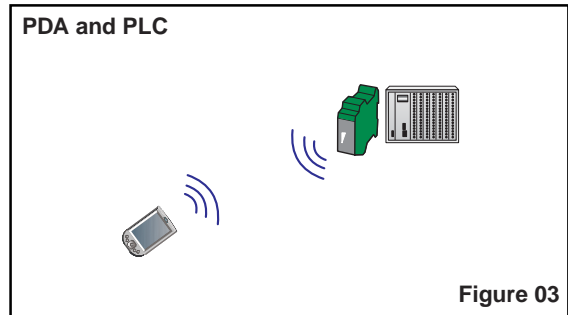

- Connection between a mobile operator interface and an industrial controller (Figure 04).

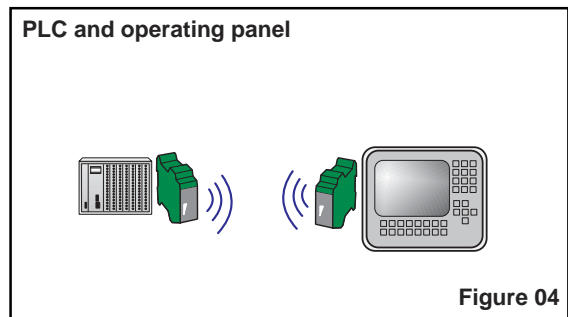

Point-to-Point With Termination Device Addressing (RS-485 2-Wire)

- Integration of a device into an existing bus system, e.g., Modbus, PROFIBUS, etc. (Figure 05).

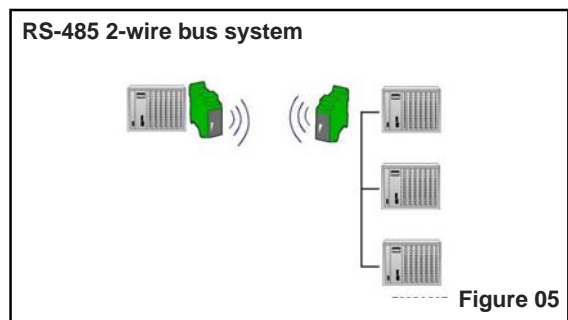

2.2 Multi-Drop Connections

Networking for automation components. Up to seven Bluetooth slaves can be connected to a Bluetooth master (Figure 06).

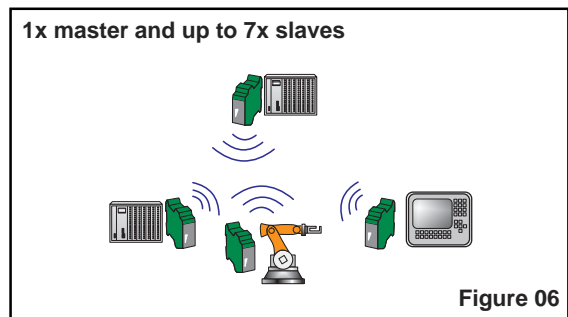

3. Technical Data

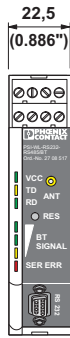
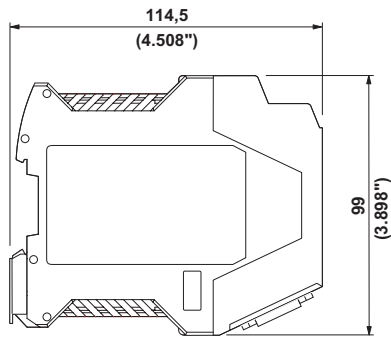

PSI-WL-RS232-RS485/BT

UL (in preparation)

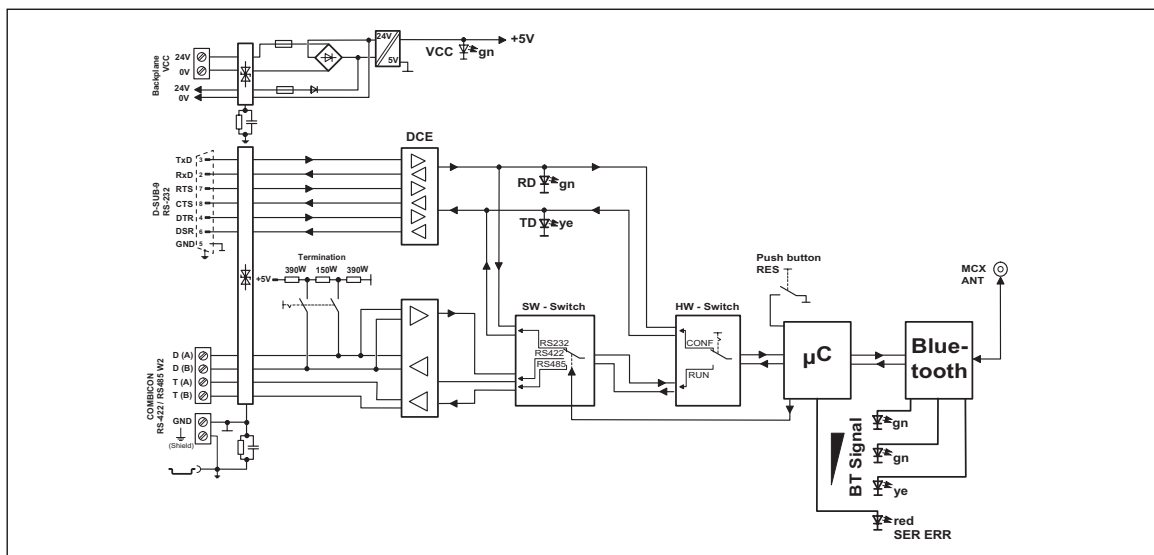

Description	Type	Order No.	Pcs. Pkt.
Bluetooth converter for converting V.24 (RS-232)/RS-422/RS-485 2-wire to Bluetooth, range up to 150 m, DIN rail mounting, 24 V supply. Scope of supply: DIN-rail mountable Bluetooth device, CD with configuration software and user manual	PSI-WL-RS232-RS485/BT	27 08 51 7	1
Accessories Lambda/4 antenna with omni-directional characteristics, mounting bracket, antenna cable with angled antenna connector.	RAD-ISM-2400-ANT-OMNI-2-1	28 67 46 1	1
Gain 1.50 m Polarization MCX Impedance 2 dBi Degree of protection Omni, vertical Dimensions 50 Ω IP65 ∅ 8.2 mm x 82.5 mm			
Panel antenna with directional characteristics, mounting clamp and antenna connection.	RAD-ISM-2400-ANT-PAN-8-0	28 67 61 0	1
Gain ∅ 40 mm to 60 mm Polarization SMA Impedance 8 dBi Degree of protection Linear, vertical Dimensions (H x W x D) 50 Ω IP55 101 mm x 80 mm x 20 mm			
Coaxial antenna cable for panel antenna.	RAD-PIG-EF316-MCX-SMA	28 67 67 8	1
Connections 1 m (3.28 ft.) Attenuation MCX/SMA Impedance 2 dB 50 Ω			

Serial Bluetooth Converter for V.24 (RS-232), RS-422, and RS-485 2-Wire Bus – PSI-WL-RS232-RS485/BT

Additional Accessories		Type	Order No.	Pcs. Pkt.
System power supply primary switched.				
Input voltage range	45 to 65 Hz 85 to 264 V AC	MINI-SYSPS-100-240AC/24DC/1.5	28 66 983	1
Nominal output voltage	24 V DC ±1%			
Nominal output current	1.5 A			
DIN rail bus connector		ME 22,5 TBUS 1,5/ 5-ST-3,81 GN	27 07 437	1
Technical Data				
Supply				
Supply voltage 1	(function elements 12 - 13)	10 to 30 V DC, 24 V AC ±20% Via plug-in COMBICON screw terminal block Protection against polarity reversal via bridge rectifier		
Supply voltage 2 (alternative or redundant)		24 V DC ±20% Via backplane bus contact and appropriate system power supply, protection against polarity reversal via series diode.		
Frequency		DC or 50 to 60 Hz		
Nominal current consumption		40 mA at 24 V DC 70 mA RMS at 24 V AC		
LED indicator	(function element 9)	VCC (green LED): - Steady light during operation in RUN mode - Flashing during operation in CONF mode		
Configuration				
System requirements		Windows 98 SE, 2000, NT4, XP		
Configuration interface		V.24 (RS-232), Bluetooth, The system is configured in CONF mode via the V.24 (RS-232) interface and the configuration software provided. Either the local device is configured or a remote device is configured via Bluetooth.		
V.24 (RS-232) Interface				
Physics		EIA/TIA RS-232		
Connection	(function element 1)	9-pos. D-SUB pin strip		
Device type		DCE (Data Communication Equipment) with 1:1 cable to DTE (Data Terminal Equipment).		
Signal assignment		TxD = 3, RxD = 2, RTS = 7, CTS = 8, DTR = 4, DSR = 6, GND = 5		
Data format		Serial asynchronous UART/NRZ		
Encoding		7/8 data, 1/2 stop, 1 parity, 10/11-bit character length can be adjusted via software.		
Protocols		Transparent protocol, including 3964R protocol		
Serial transmission speed		0.3, 1.2, 2.4, 4.8, 7.2, 9.6, 19.2, 31.25, 38.4, 57.6, 75, 93.75, 115.2, 136, 187.5 kbps can be adjusted via software.		
Data flow control		Hardware handshake: - Termination device directly with the Bluetooth converter via RTS/CTS - Data transmission speed of up to 187.5 kbps Software handshake (Xon/Xoff): - Software handshake is negotiated directly between the termination devices - Setting on Bluetooth converter = "none" - Data transmission speed of up to 38.4 kbps Message-oriented protocols, e.g., Modbus, PROFIBUS, etc.: - Setting on Bluetooth converter = "none" - Data transmission speed of up to 93.75 kbps		
Default upon delivery		9.6 kbps, 8 data, no parity, 1 stop bit, hardware handshake		
LED indicator/serial data indicator	(function elements 7 - 8)	TD (yellow LED), dynamic, serial port is transmitting data, RD (green LED), dynamic, serial port is receiving data		
LED indicator/serial system diagnostics	(function element 2)	SER ERR (red LED), parity error, handshake error, buffer data overrun		

Serial Bluetooth Converter for V.24 (RS-232), RS-422, and RS-485 2-Wire Bus – PSI-WL-RS232-RS485/BT

RS-422/RS-485 2-Wire		
Physics		EIA/TIA RS-422 and RS-485 2-wire, can be switched via configuration software, default upon delivery is V.24 (RS-232)
Connection	(function elements 10 - 11, 14 - 17)	Plug-in COMBICON screw terminal block
Termination resistor/termination	(function element 19)	390 - 150 - 390 Ω can be enabled in the device, default upon delivery is OFF
Signal assignment for RS-422		Transmit pos. = TB, Transmit neg. = TA, Receive pos. = DB, Receive neg. = DA Signal ground = GND, Shield connection = FE
Signal assignment for RS-485 2-wire		Transmit/Receive pos. = DB, Transmit/Receive neg. = DA
Bluetooth Interface		
Physics		Bluetooth 1.1 Specification
Frequency		2.402 GHz to 2.480 GHz (ISM band 2.4 GHz)
Channel distance		1 MHz
Bandwidth		79 MHz
Channels		79
Transmission method		Frequency hopping 1.6 kHz (FHSS)
Radio approvals	USA (in preparation): Canada (in preparation): Europe: Approved countries:	FCC/CFR 47, Part 15 RSS-210 ETSI EN 300 328, 300 826 EU countries: Belgium, Denmark, Germany, Estonia, Finland, France, Greece, Great Britain, Ireland, Italy, Latvia, Lithuania, Luxembourg, Malta, Netherlands, Austria, Poland, Portugal, Sweden, Slovakia, Slovenia, Spain, Czech Republic, Hungary, Cyprus Non-EU countries: Iceland, Norway, Switzerland, USA, Canada Other countries on request
Notification		EU countries, Iceland, Switzerland, Norway
R&TTE device class		Class 2
Usage restrictions according to ERC Recommendation 70-03/April 2004		France: Outside buildings the maximum transmission power is 10 mW (10 dBm), (note antenna data and software settings) Italy: Outside buildings a license is required for operation and the maximum transmission power is 10 mW (10 dBm), (note antenna data and software settings)
Bluetooth device class		Class 1 = 100 mW (20 dBm), maximum
Transmission power		20 dBm = default upon delivery, can be set via software from -28 dBm to +20 dBm
Range guide values (depending on the application environment)		20 dBm = 80 m to 150 m 10 dBm = 40 m to 70 m 0 dBm = 10 m to 30 m
Receiver sensitivity		-80 dBm at 0 dBi antenna gain
Antenna		External antenna, not included in the scope of supply, (see list of accessories)
Antenna connection	(function element 18)	MCX
Bluetooth profile		- GAP (Generic Access Profile) (method for authentication and connection establishment) - SDAP (Service Discovery Application) (method for requesting supported services) - SPP (Serial Port Profile) (COM port emulation method) - DUN (Dial-up Networking Profile) (modem dial-up method) - LAP (LAN Access Point Profile) (network connection method)
Number of Bluetooth masters/Bluetooth slaves		1x master/7x slaves
LED indicator/Bluetooth data indicator	(function element 3)	BT SIGNAL (1x yellow LED flashing), Bluetooth is transmitting/receiving data
LED indicator/Bluetooth transmission quality	(function elements 3 - 5) (function elements 3 - 4) (function element 3)	BT SIGNAL (1x yellow LED, 2x green LEDs), very good reception BT SIGNAL (1x yellow LED, 1x green LED), good reception BT SIGNAL (1x yellow LED), poor reception, close to the system reserve

Serial Bluetooth Converter for V.24 (RS-232), RS-422, and RS-485 2-Wire Bus – PSI-WL-RS232-RS485/BT

General Data

CE conformance	According to R&TTE Directive 1999/5/EC
Approvals	UL (in preparation)
Ambient operating temperature range during operation	-20°C to +60°C.
Housing	ME 22.5 LWL LINE with 5-pos. ME-T bus contact and ground contact
- Material	ABS-VO, green
- Dimensions (H x W x D in mm)	99 x 22.5 x 114.5 mm
Weight of device	120 g, approximately
Functional earth ground	Housing contact with DIN rail
Vibration resistance	According to DIN EN 60068-2-6 5g, 2.5 h in each x, y, and z direction Criterion A (no functional disruption)
Shock test	According to DIN EN 60068-2-27 15 g, 11 ms pulse length Criterion C (module is not damaged)
Free fall	According to DIN EN 60950 from a height of 1 m. without packaging
Degree of protection	IP20
Air and creepage distances	According to VDE 0110-1, DIN EN 50178, DIN EN 60950
Ambient compatibility	Free from substances, which would hinder coating with paint or varnish according to central standard P-VW 3.10.7 -3.10 0.757 650 of VW, Audi, and Seat (chloroform test)
Separate ground levels	24 V supply // 5 V logic + serial ports // functional earth ground
Test voltage	1.5 kV AC, 50 Hz, 1 min. between all ground levels according to EN 50 178 and EN 61 131-2



According to R&TTE Directive 1999/5/EC:

EMC¹⁾ Noise immunity (Electromagnetic Compatibility)	EN 61000-6-2:2001	Generic standard for the industrial sector
Safety Protection of personnel with regard to electrical safety.	EN 60950 : 2001	
Health Limitation of exposure of the population to electromagnetic fields.	EC Gazette 1999/519/EC	EC Council recommendation of July 12, 1999
Radio Effective use of the frequency spectrum and prevention of radio interference.	ETSI EN 300 328: V1.2.1, V1.4.1	

¹⁾ Addition: EMC (Electromagnetic Compatibility)

Noise Immunity According to EN 61000-6-2		
• Electrostatic discharge (ESD)	EN 61000-4-2	8 kV air discharge ²⁾ 6 kV contact discharge ²⁾
• Electromagnetic HF field Amplitude modulation Pulse modulation	EN 61000-4-3	10 V/m ¹⁾ 10 V/m ¹⁾
• Fast transients (burst) Signal: Supply:	EN 61000-4-4	2 kV/2 min. ²⁾ 2 kV/2 min. ²⁾
• Surge current loads (surge) Signal: Supply:	EN 61000-4-5	1 kV/42 Ω ²⁾ 0.5 kV/2 Ω symmetrical ²⁾ 0.5 kV/12 Ω asymmetrical ²⁾
• Immunity to conducted interference	EN 61000-4-6	10 V/m ¹⁾
• Noise emission: Conducted emission Radiated emission	EN 55011 ETSI EN 300 328	Class A

EN 61000 corresponds to IEC 1000
EN 55011 corresponds to CISPR11

¹⁾ Criterion A: Normal operating characteristics within the specified limits.

²⁾ Criterion B: Temporary adverse effects on the operating characteristics that the device corrects automatically.

Class A: Industrial application, without special installation measures.

4. Function Elements/Diagnostics

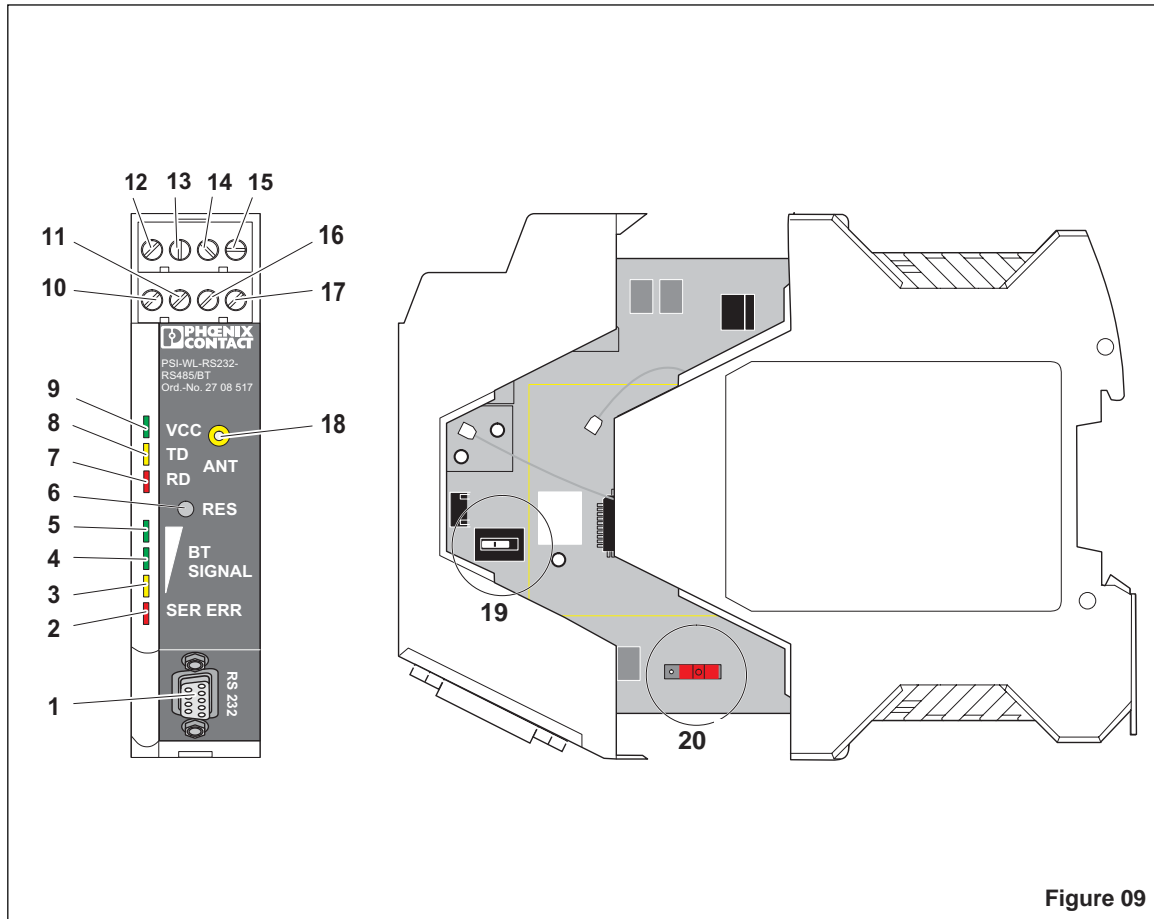

Figure 09

- | | |
|--|--|
| <ul style="list-style-type: none"> 1. 9-pos. D-SUB, V.24 (RS-232) data interface 2. Red LED, incorrect interface setting or buffer overrun 3. Yellow LED, poor reception, close to the system reserve 4. Green LED, good reception 5. Green LED, very good reception 6. Pushbutton, to reset settings 7. Green LED, dynamic, serial port is receiving data 8. Yellow LED, dynamic, serial port is transmitting data 9. Green LED, steady light during operation in RUN mode, flashing during operation in CONF mode 10. ↓, shield connection | <ul style="list-style-type: none"> 11. GND, operating ground 12. VCC, supply of 10 to 30 V DC, 24 V AC $\pm 20\%$ 13. 0 V, supply of 0 V 14. TA, RS-422: Transmit negative 15. TB, RS-422: Transmit positive 16. DA, RS-422: Receive negative
RS-485 2-wire: Transmit/Receive negative 17. DB, RS-422: Receive positive
RS-485 2-wire: Transmit/Receive positive 18. MCX connection, for external antenna 19. Switch for RS-422/RS-485 Terminate ON/OFF 20. Switch for CONF/RUN |
|--|--|